

HB47V

TRUCK-MOUNTED CONCRETE PUMP
MANUFACTURED BY XCMG SCHWING

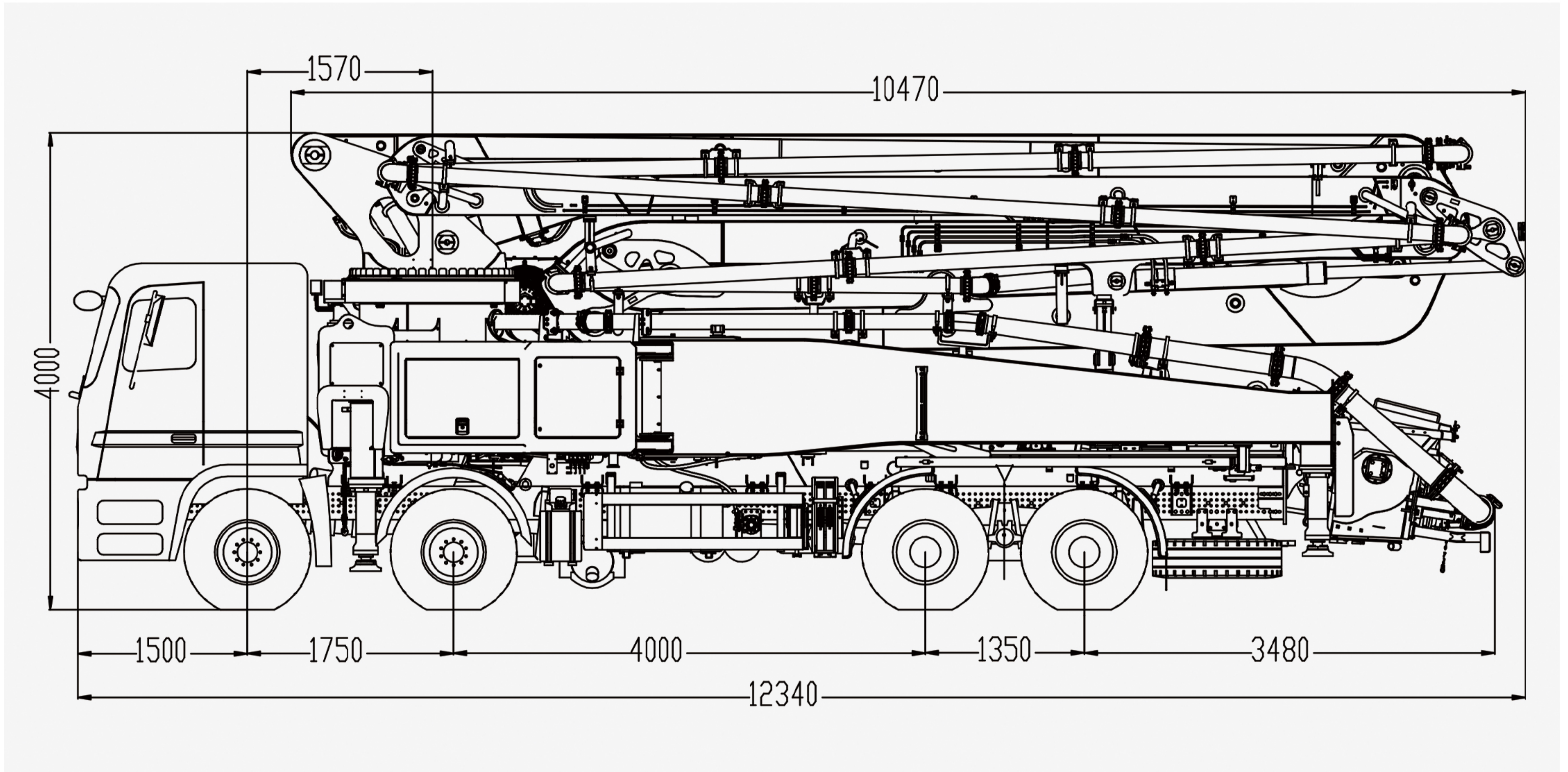

Note: Dimensions and weights depend on truck and equipment. Dimensions in mm.

Technical Data

Pump			
Concrete output max.	m ³ /h		170
Pressure on concrete max.	MPa		10.2
Maximum aggregate diameter	mm		40
Concrete cylinder diameter/stroke	mm		260/2000
Strokes	1/min.		25~27
Concrete valve			Rock valve
Hydraulic system type			Open

Support			
Full support	Outrigger width,front	mm	8300
	Outrigger width,rear	mm	9820
	Outrigger width,side	mm	9140
One-side support	Outrigger width,front	mm	5270
	Outrigger width,rear	mm	6190
Load	Outrigger load,front	kN	230
	Outrigger load,rear	kN	230

Note: All data maximum theoretical

Boom			
Reach height	m		47.05
Horizontal reach	m		42.05
Net horizontal reach	m		37.94
Reach depth	m		30.40
Slewing range	°		± 360
Diameter of delivery pipe	mm		125
Unfolding height	m		13.30
Quantity and folding type			5RZ
Length of end hose	m		3.00
1 st section unfolding angle	°		90
2 nd section unfolding angle	°		180
3 rd section unfolding angle	°		180
4 th section unfolding angle	°		230
5 th section unfolding angle	°		200
1 st section length	mm		9630
2 nd section length	mm		7590
3 rd section length	mm		7660
4 th section length	mm		9085
5 th section length	mm		9094



Working Range

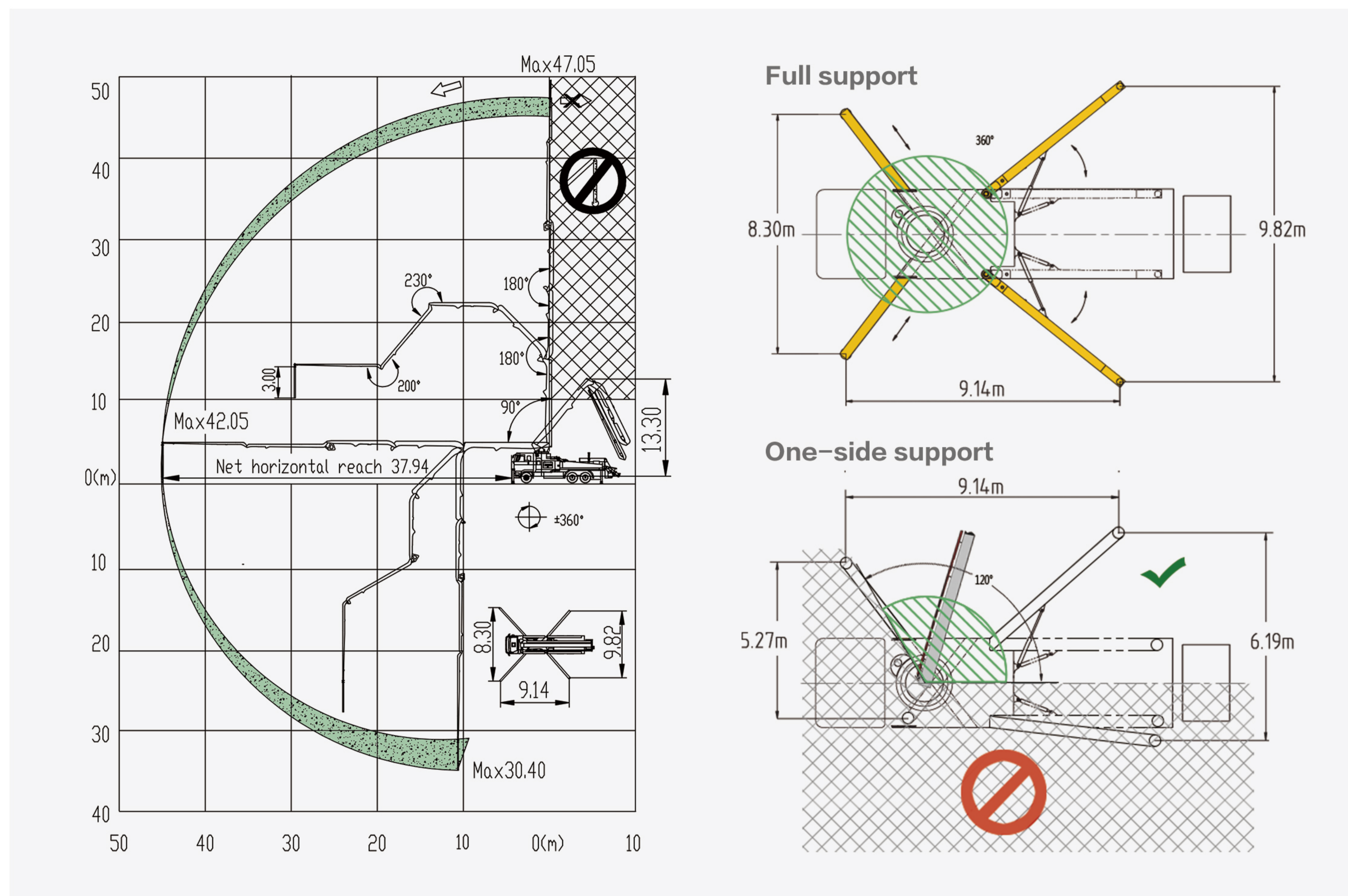

Configuration Features

Overall Structure

- 5RZ bionic folding boom
- NDT of boom critical weld seam
- Large rigid hollow turret
- Two-level X-shaped telescoping outrigger
- Pass-through delivery pipe support

Pumping System

- Rock valve pumping technology
- Electric control reversing
- Central pump elastic suspension
- Automatic wear ring compensation
- Piston one-key return

Hydraulic System

- SCHWING main valve
- Open hydraulic system
- Large displacement hydraulic control cooling system
- Integrated hydraulic control system
- Full-flow hydraulic oil filtration

Delivery System

- Streamline pipe arrangement
- Anti-caking hopper
- Large diameter climbing pipe
- Large and medium-sized delivery pipe elbow
- Assisted opening feed hopper cover

Control System

- SCHWING intelligent control technology
- Remote control and fault diagnosis
- SCHWING's 3rd generation energy-saving technology
- Grating switch detection
- Outrigger Limited warning

Others

- Water tank capacity 820L
- Water pipe length 20m
- Outlet pressure(7Mpa) of water gun
- One-key pneumatic greasing of lubrication system
- One-side operation function

